

1 2 3 4 5 6

PART #	DESCRIPTION	MATERIAL	QTY.
7000286	30mm U WITH V	N/A	1
180028	1/2-13x1.25 HCS	Zinc-Plated Steel	1
7010290	30mm COMBO FLAT LID/KNOB/SHAFT	N/A	1
180014	1/2" FLAT WASHER	18-8 STAINLESS STEEL	2
180015	1/2" SPLIT LOCK WASHER	18-8 STAINLESS STEEL	1
180005	Plated Steel Hex Nut	GRADE 8 ZINC & YELLOW CHROMATE	1

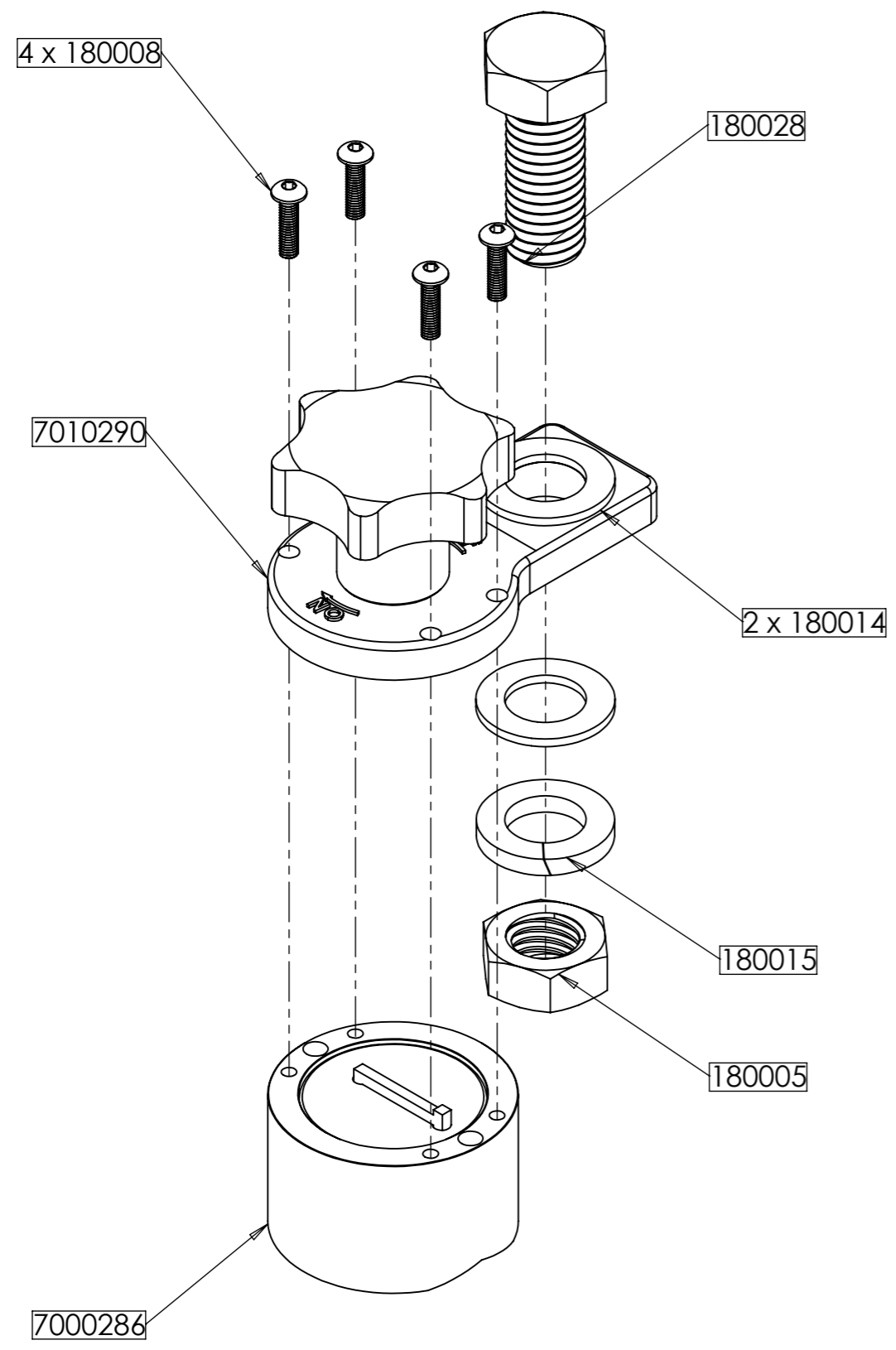

NOTES:

- TORQUE SCREWS (180008) TO 10inlbs ± 2inlb
- APPLY LOCTITE BEFORE ASSEMBLY OR USE PREAPPLIED SCREWS
- ZINC PLATING (7000286) IS PER QQ-Z-325. PLATING IS TO PASS SALT SPRAY ASTM B117
- MAGNETS ARE NDFEB COMPOSITION PER MMPA STANDARD NO. 0100-00
- SOLID PTFE AND PETROLIUM GREASE MAY CONTAIN PTFE PARTICLES (7000286)
- COMPONENTS MAY MEET OTHER STANDARDS PROVIDED THAT PERFORMANCE IS EQUAL
- VERIFY ACTUATION MATCHES ARROWS

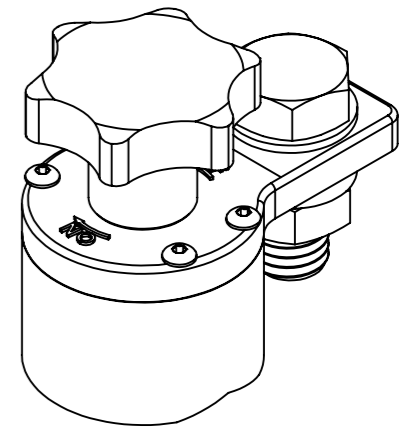

THIS DOCUMENT, AND THE INFORMATION IT CONTAINS, INCLUDING THE PRINCIPLES OF DESIGN, IS THE EXCLUSIVE PROPERTY OF MAGSWITCH TECHNOLOGY, INC. AND IS CONFIDENTIAL. ACCORDINGLY, THIS INFORMATION IS SUBMITTED TO YOU WITH THE AGREEMENT THAT IT IS NOT TO BE REPRODUCED, COPIED, OR LOANED IN PART OR IN WHOLE, NOR IS THE INFORMATION TO BE RELAYED TO ANY OTHER INDIVIDUAL OR COMPANY EXCEPT AS MTI FIRST AUTHORIZES IN WRITING. ACCEPTANCE OF THIS DOCUMENT CONSTITUTES AGREEMENT TO THESE RESTRICTIONS.

INTERPRET DRAWING PER: ANSI Y14.5M-1994	DRAWN AARON HALE	DATE 01/05/2009
DIMENSIONS ARE IN MILLIMETERS	DESIGN	DATE
 THIRD ANGLE PROJECTION	STD. CHECK	DATE
	F/F CHECK	DATE
DO NOT SCALE	APPROVED JOHN FISHER	DATE 01/05/2009

621 SOUTHPARK DRIVE, UNIT 1900
 LITTLETON, COLORADO 80120
 303-468-0662 / FAX 303-690-8144

TITLE: **30mm U 300 AMP WGC**

SIZE A3	CAGE CODE	DWG. NO. 8000315	REV 05
SCALE 1:2		WEIGHT: g	SHEET 1 OF 1

1 2 3 4 5 6

A

A

B

B

C

C

D

D